

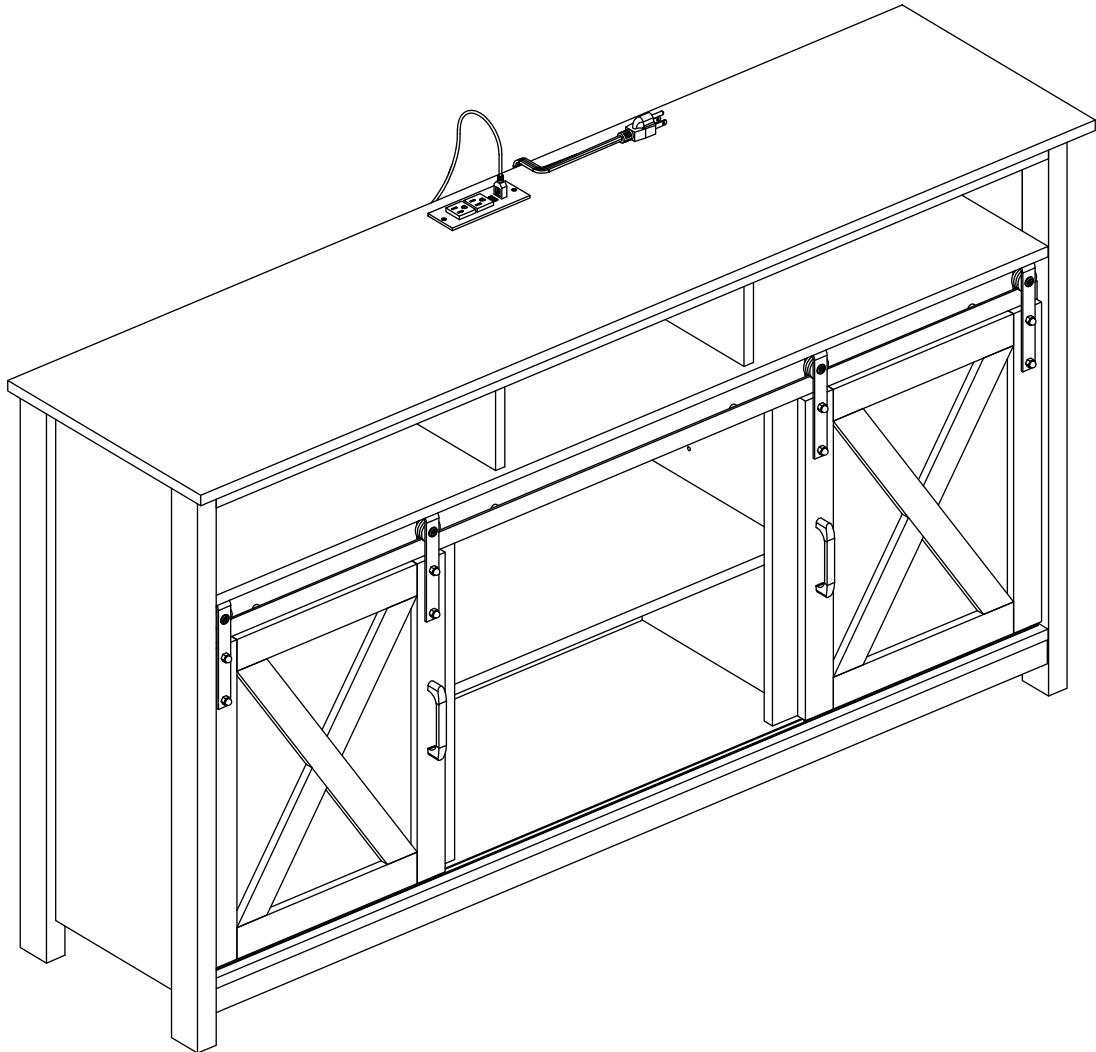

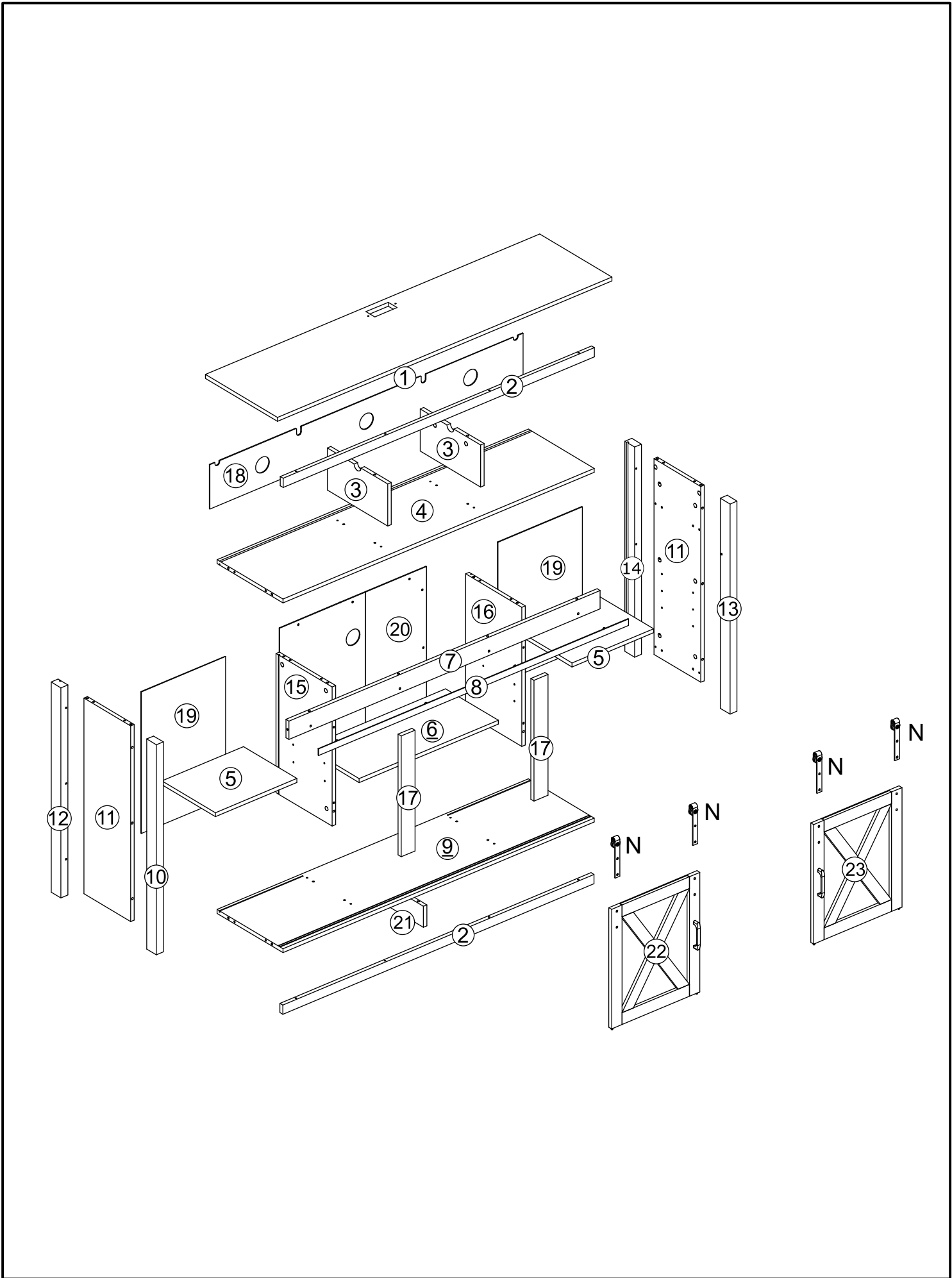



DJ0100



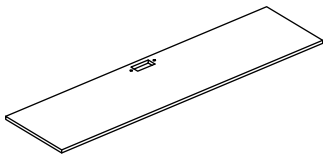
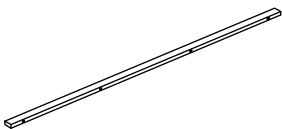

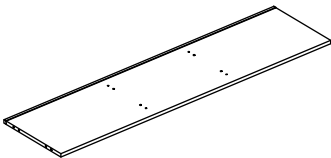
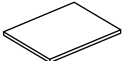
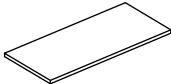
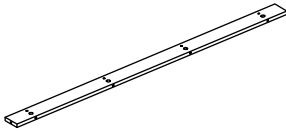
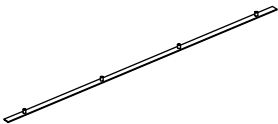
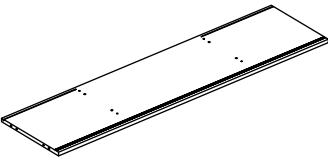
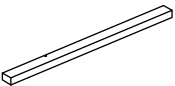
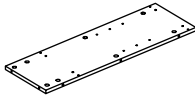
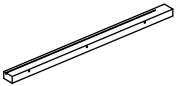
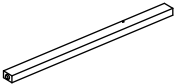
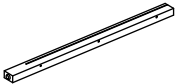
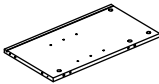
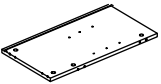

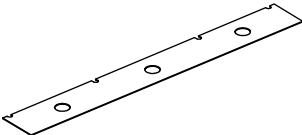
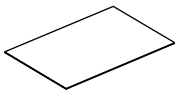
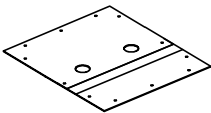

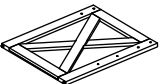
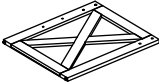



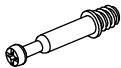

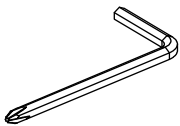

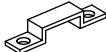
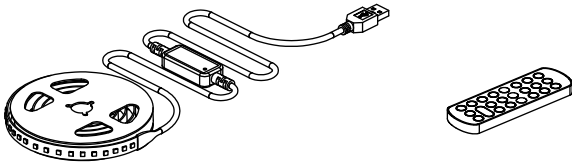

Fancyqube Locker Installation Instructions

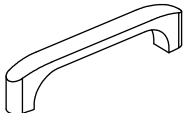
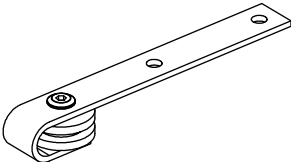

Parts and Operation Elements

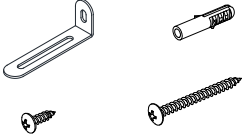
			
① Top board 1pc	② Top/Bottom support bar 2pcs	③ Upper vertical board 2pcs	④ Middle fixed shelf 1pc
			
⑤ Left/Right adjustable shelf 2pcs	⑥ Middle adjustable shelf 1pc	⑦ Middle support bar 1pc	⑧ Door rail 1pc
			
⑨ Bottom board 1pc	⑩ Left front leg 1pc	⑪ Side board 2pcs	⑫ Left hind leg 1pc
			
⑬ Right front board 1pc	⑭ Right hind leg 1pc	⑮ Left vertical board 1pc	⑯ Right vertical board 1pc
			
⑰ Vertical bar 2pcs	⑱ Upper back board 1pc	⑲ Left/Right back board 2pcs	⑳ Middle back board 1pc
			
㉑ Bottom support board 1pc	㉒ Left door panel 1pc	㉓ Right door panel 1pc	

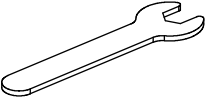
Hardware

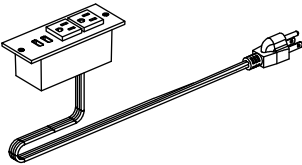
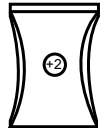
			
A	B	C	D
42+2pcs	42+2pcs	26+2pcs	1pc
			
E	F	G	H
12+2pcs	8+2pcs	12+2pcs	5pcs
			
I	1set		
			
J	K	L	M
8+2pcs	12+2pcs	4pcs	2pcs
			
N	O	P	Q
4pcs	8+2pcs	2set	2pcs
			
R	S	T	Please put the hardware of +2 in this self sealing bag
1pc	10+2pcs	1pc	

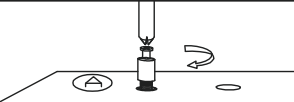
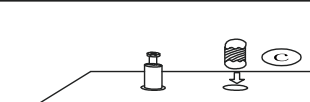
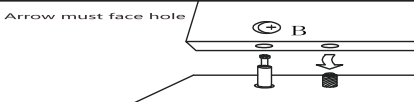
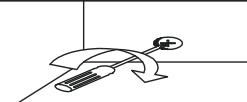
			
Gently screw cam bolt into the threaded anchor.	Insert the wood dowel halfway into hole.	Arrow must face hole.	Screw the camlock firmly into locked position.

'SAFETY TIPS:

Static charge may cause dust on foam- clean with a dry or damp cloth.

Smafoam strands may represent - handle gently and dispose of properly.

Do not burn or incinerate.

Check local recycling guidelines.

1

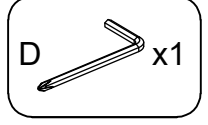
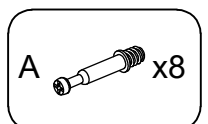
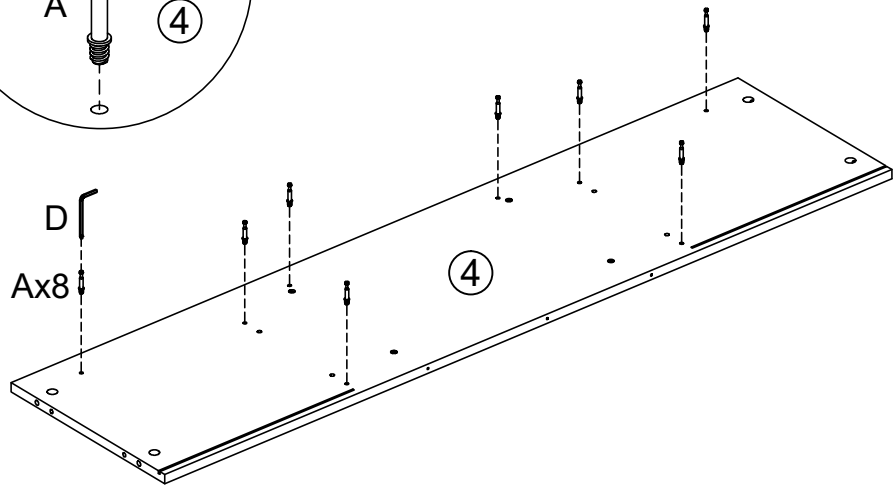
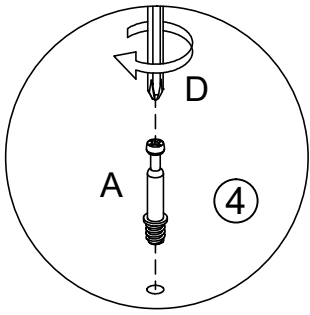

2

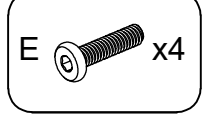
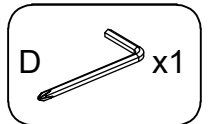
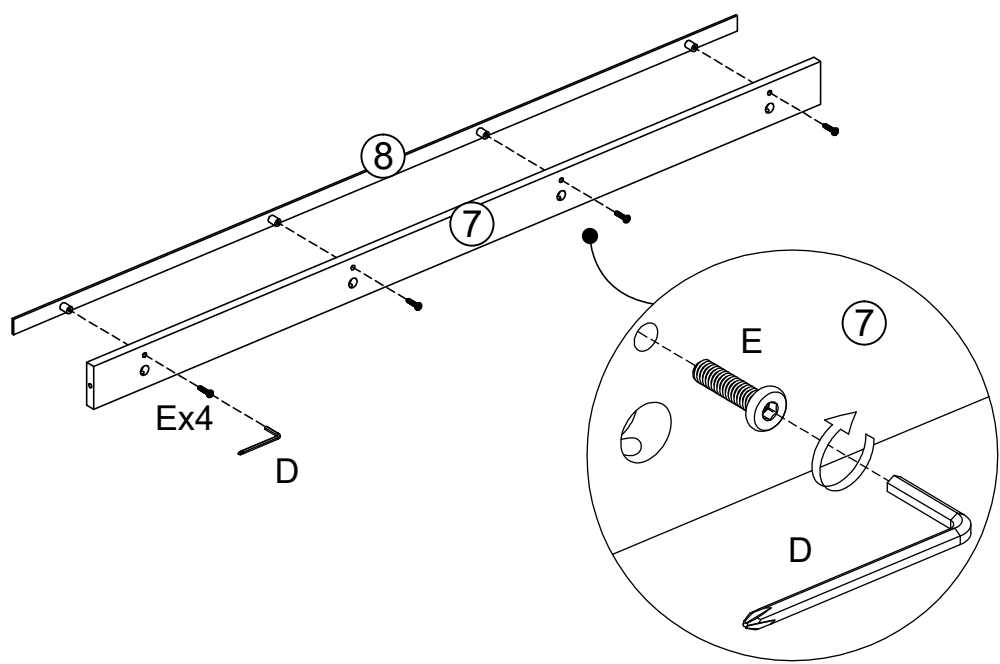

3



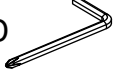

B  x4

D  x1

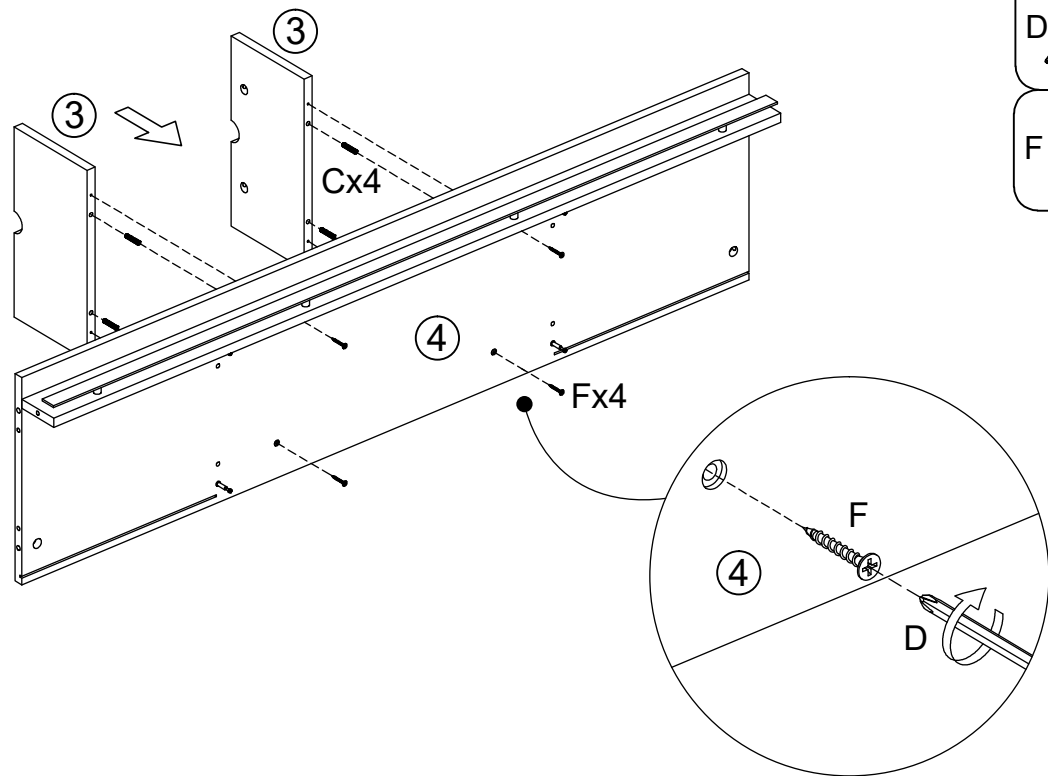
4



C  x4

D  x1

F  x4

5

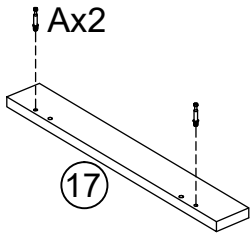

x2

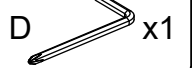
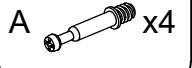
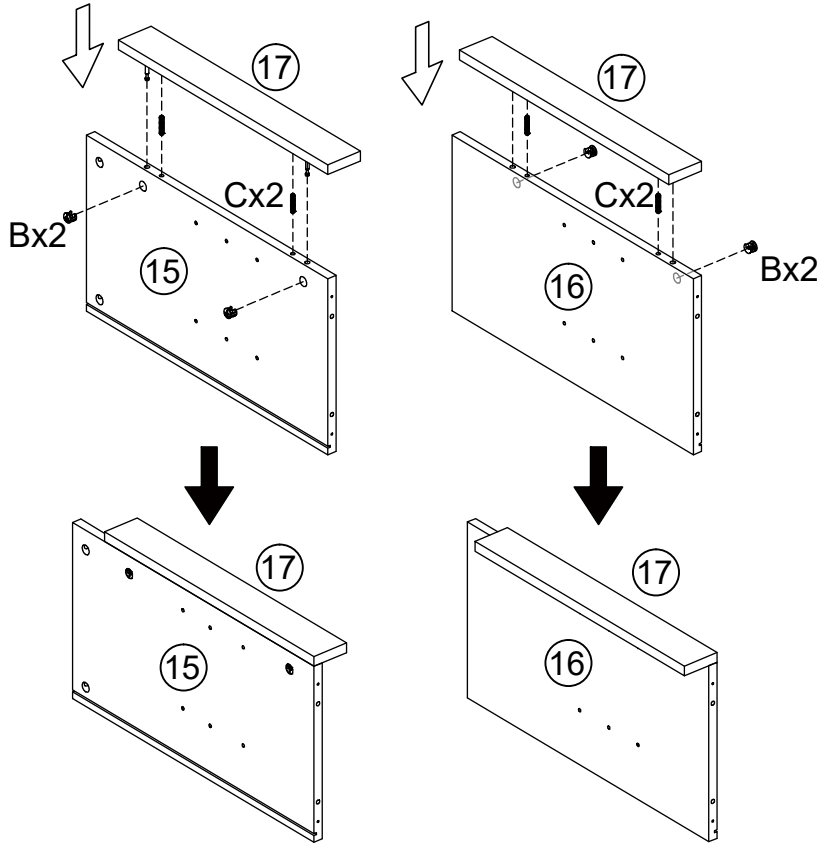

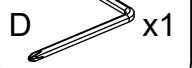
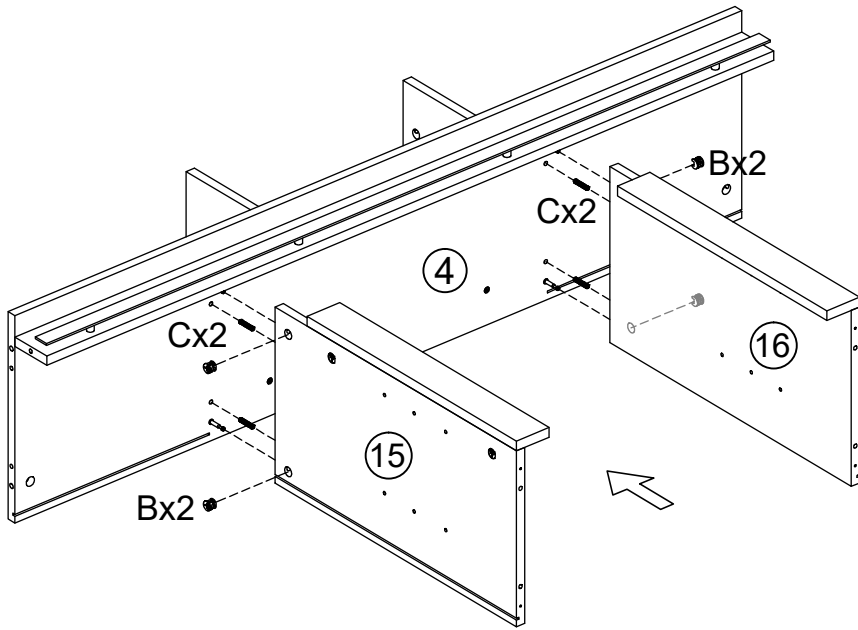

6



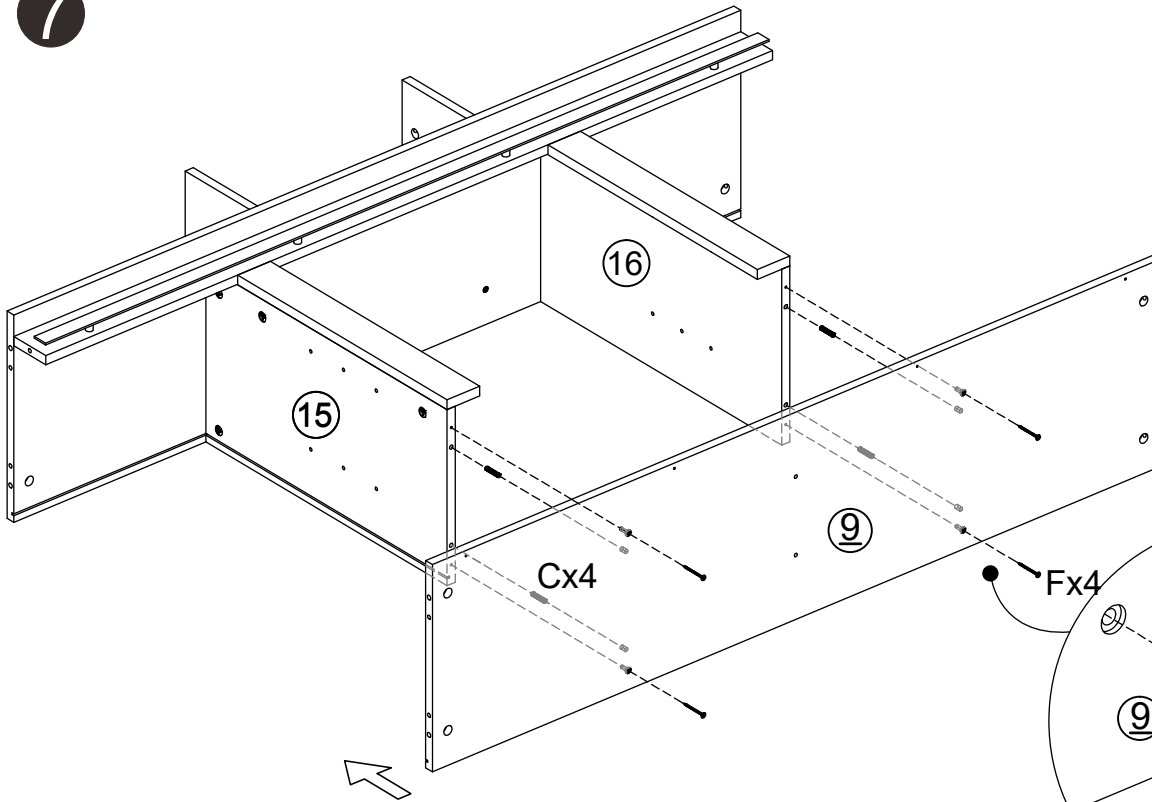

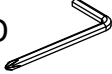
7



- C  x4
- D  x1
- F  x4

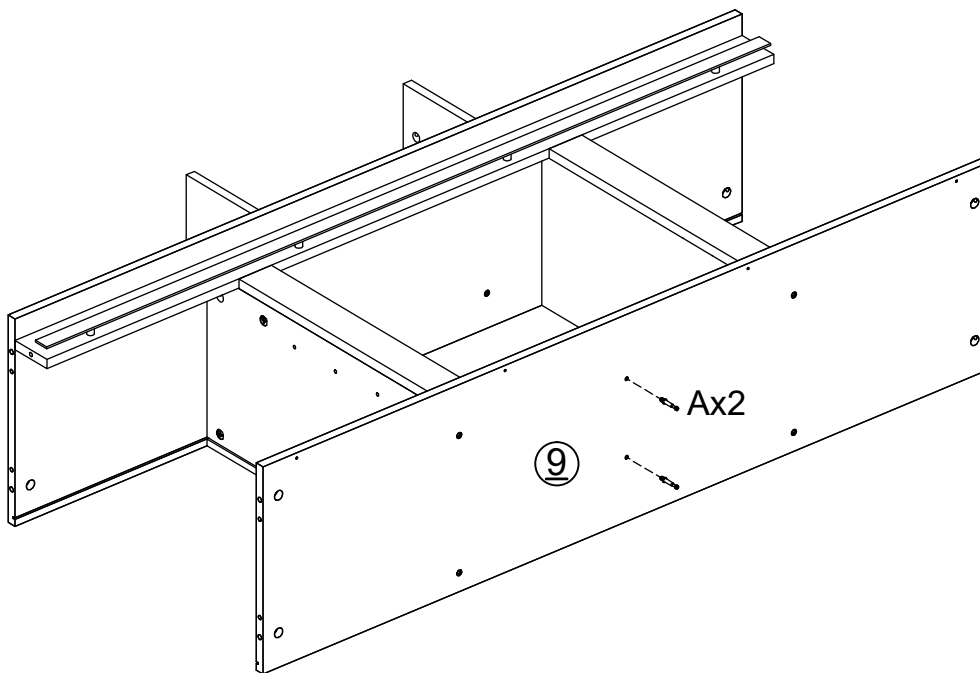

8

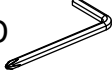

- A  x2
- D  x1

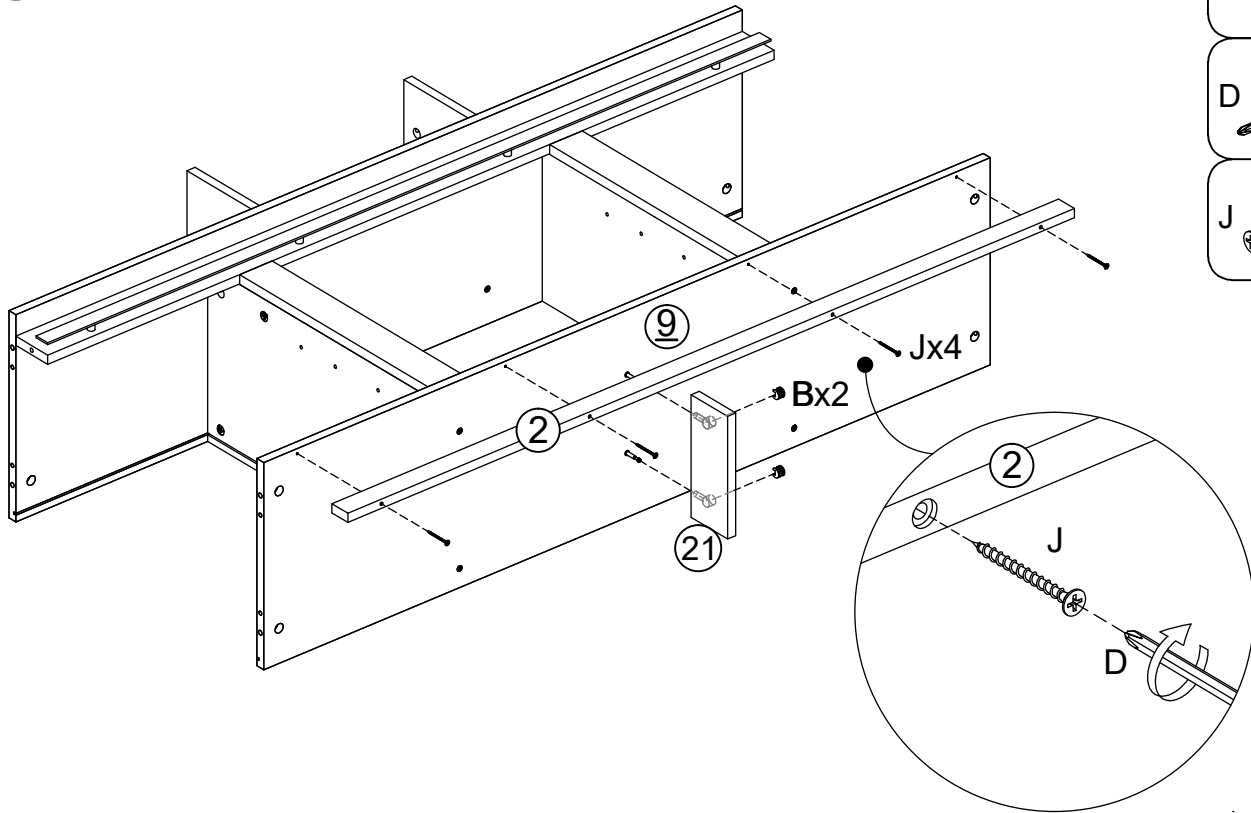
9



- B  x2
- D  x1
- J  x4

10

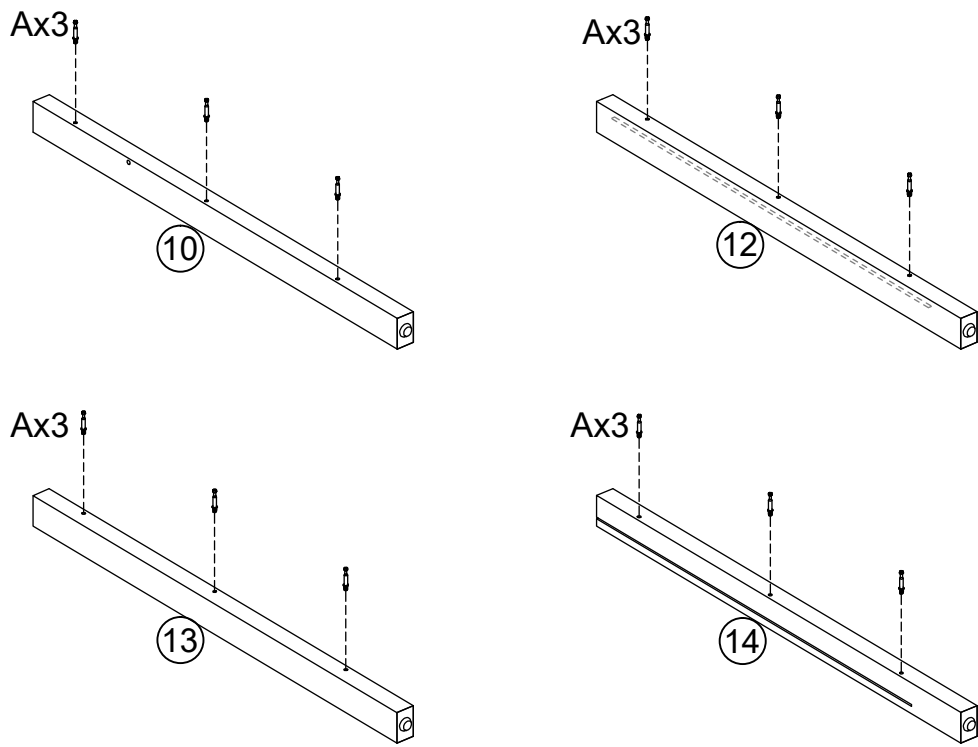

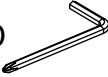
- A  x12
- D  x1

11

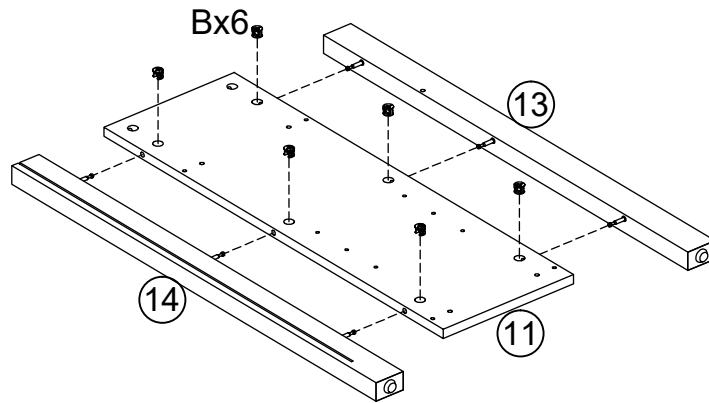
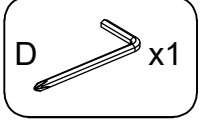
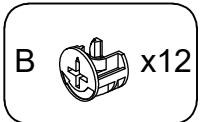
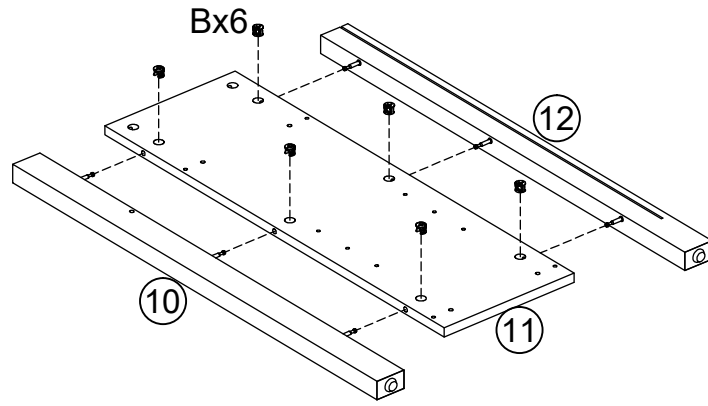

12

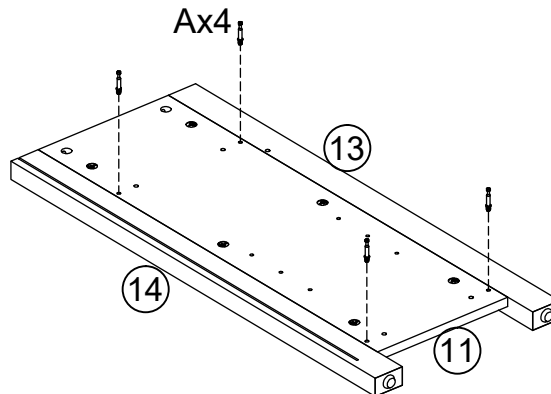
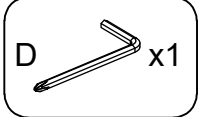
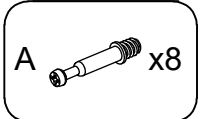
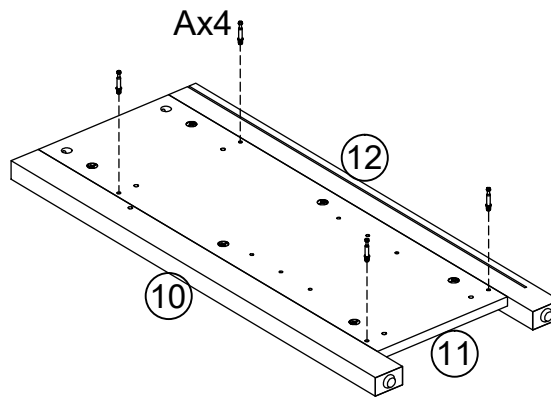

13

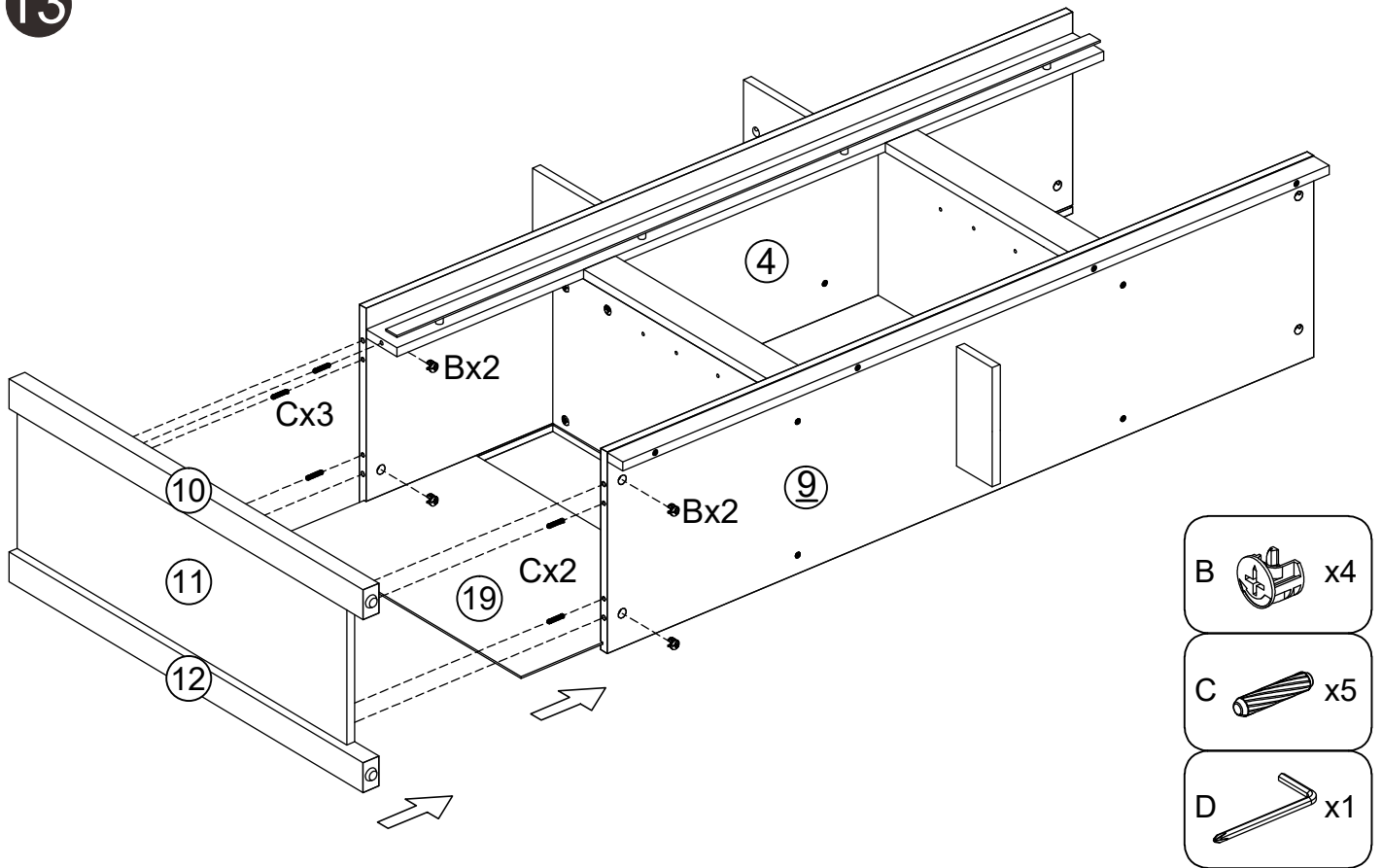

14

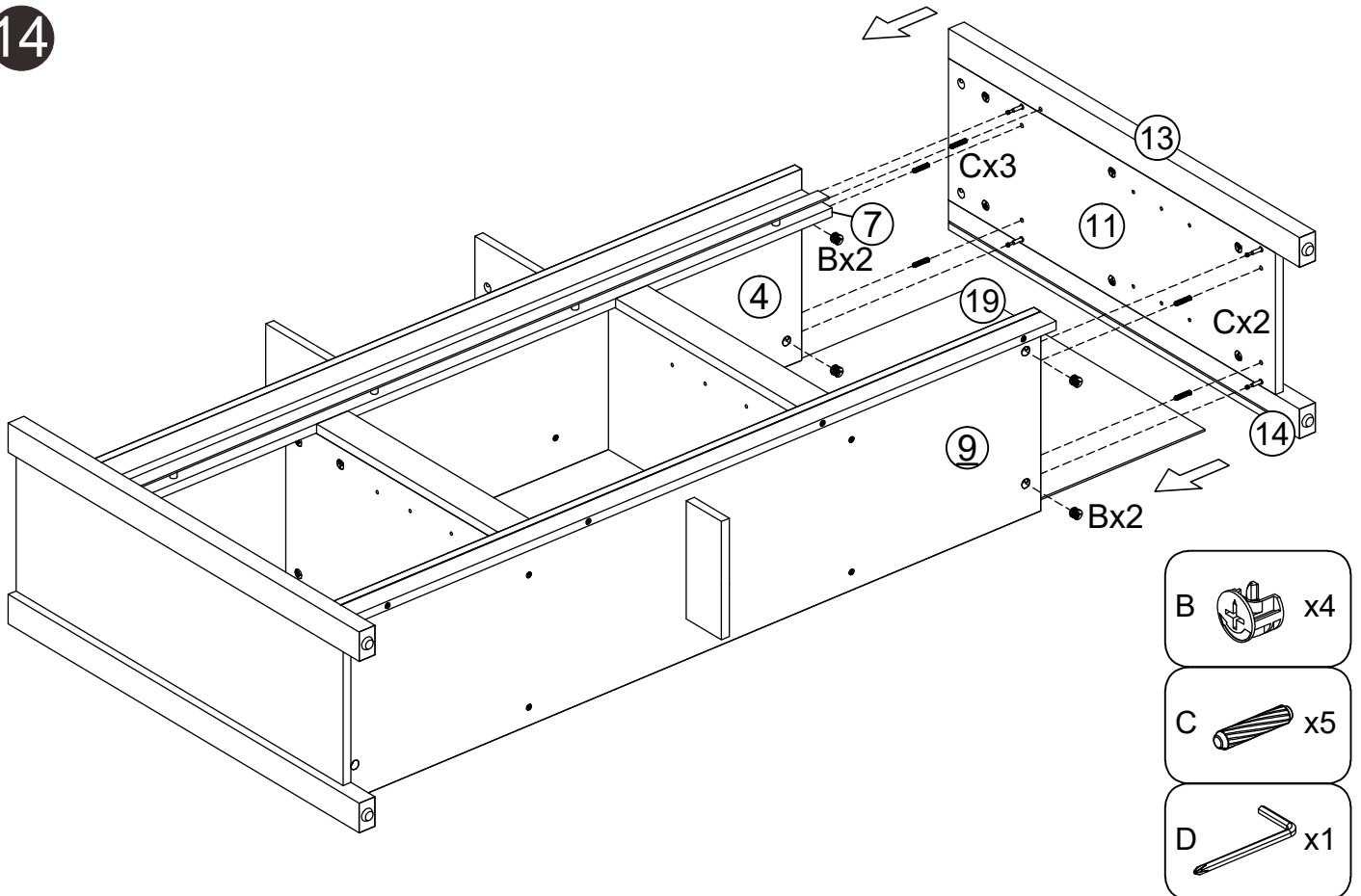

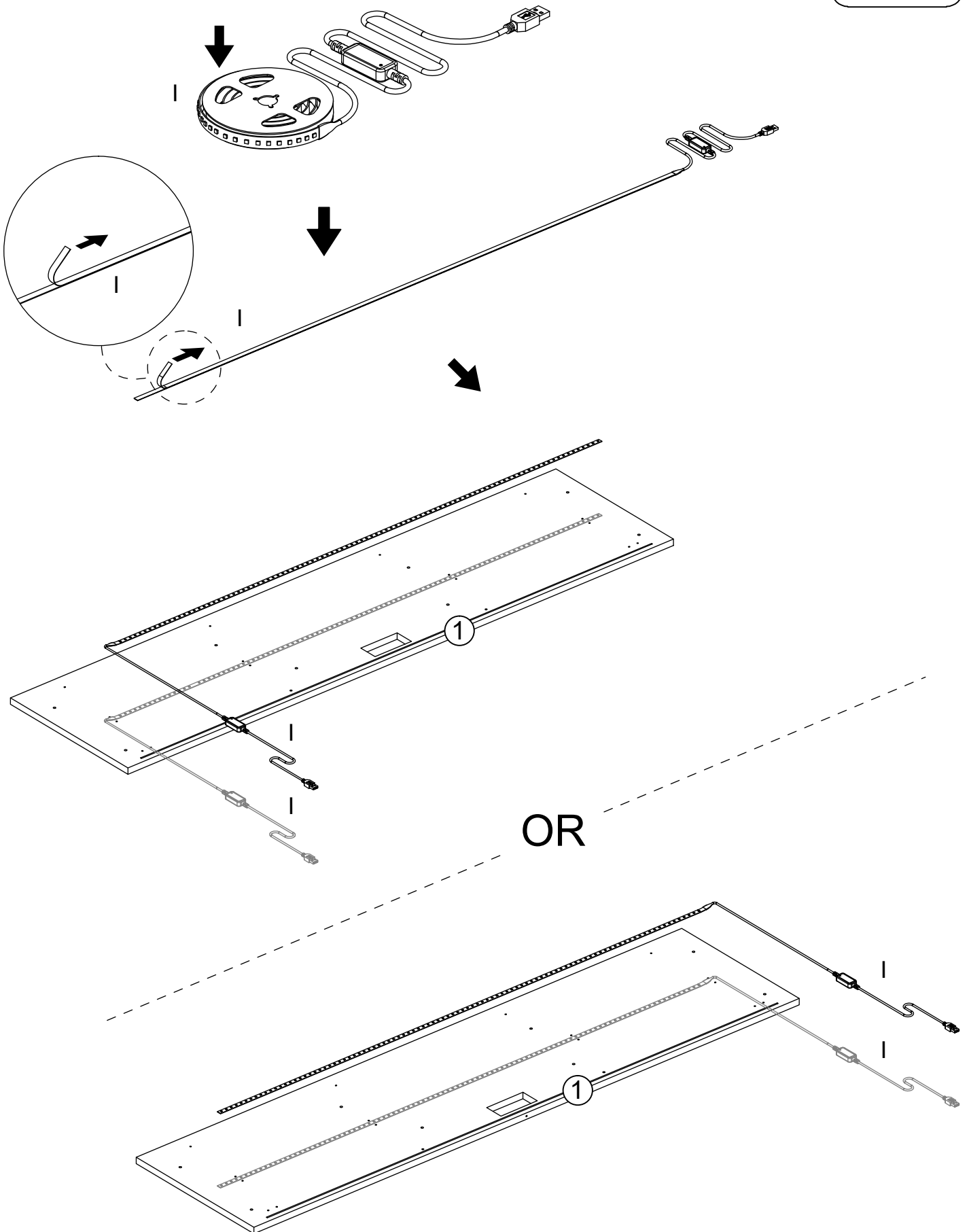
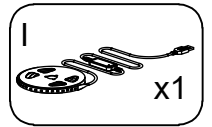

15



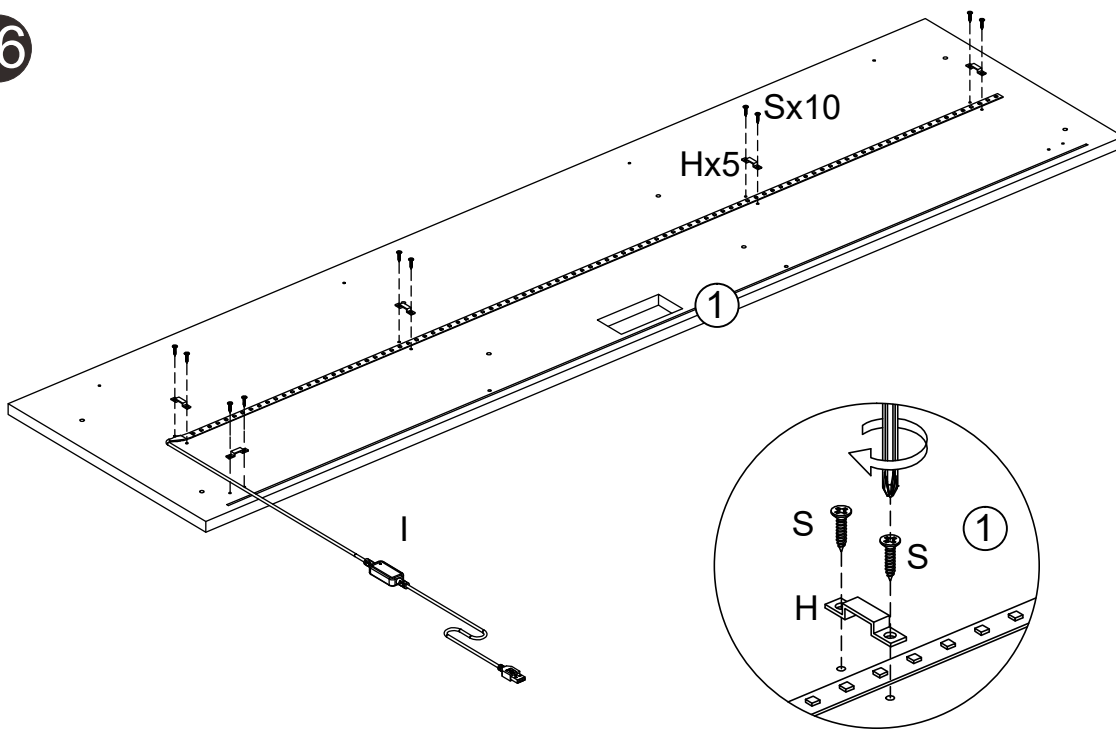

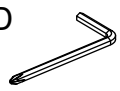
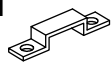

16

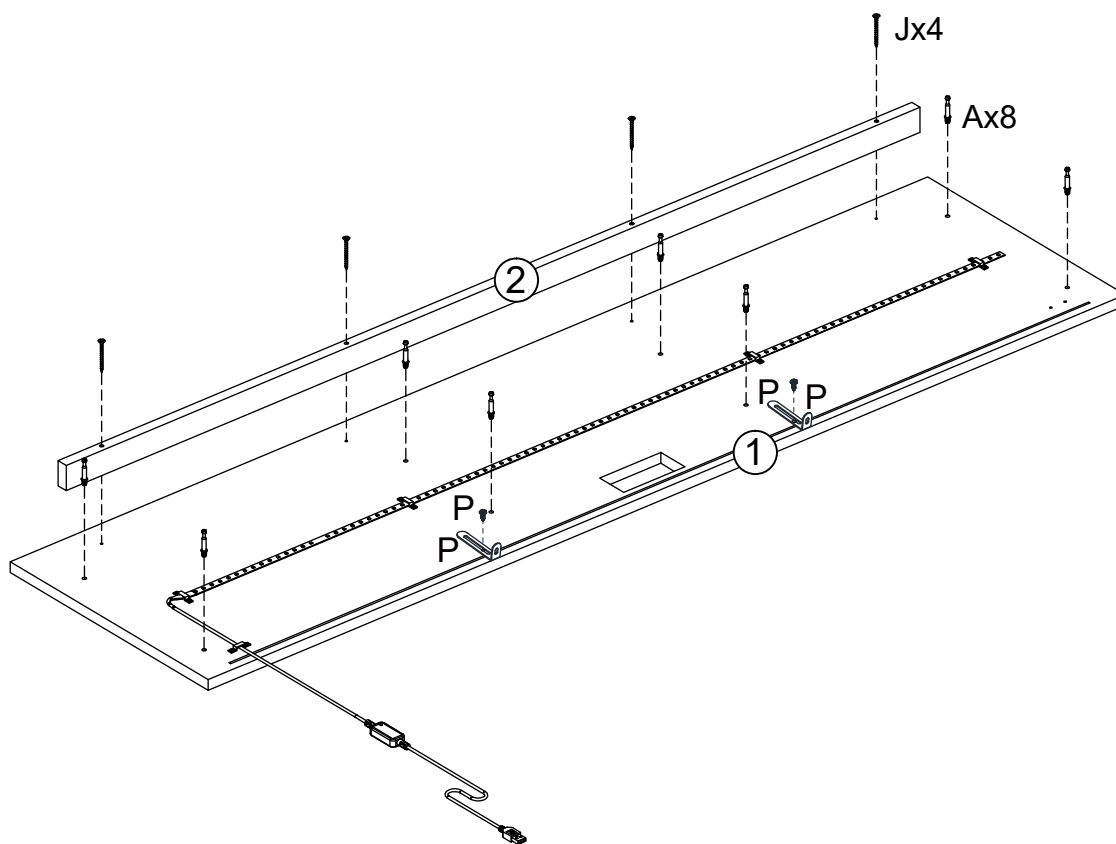

- D  x1
- H  x5
- I  x1
- S  x10

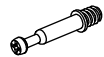
17



- A  x8
- D  x1
- J  x4
- P  x2

18

B  x8

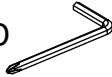
D  x1

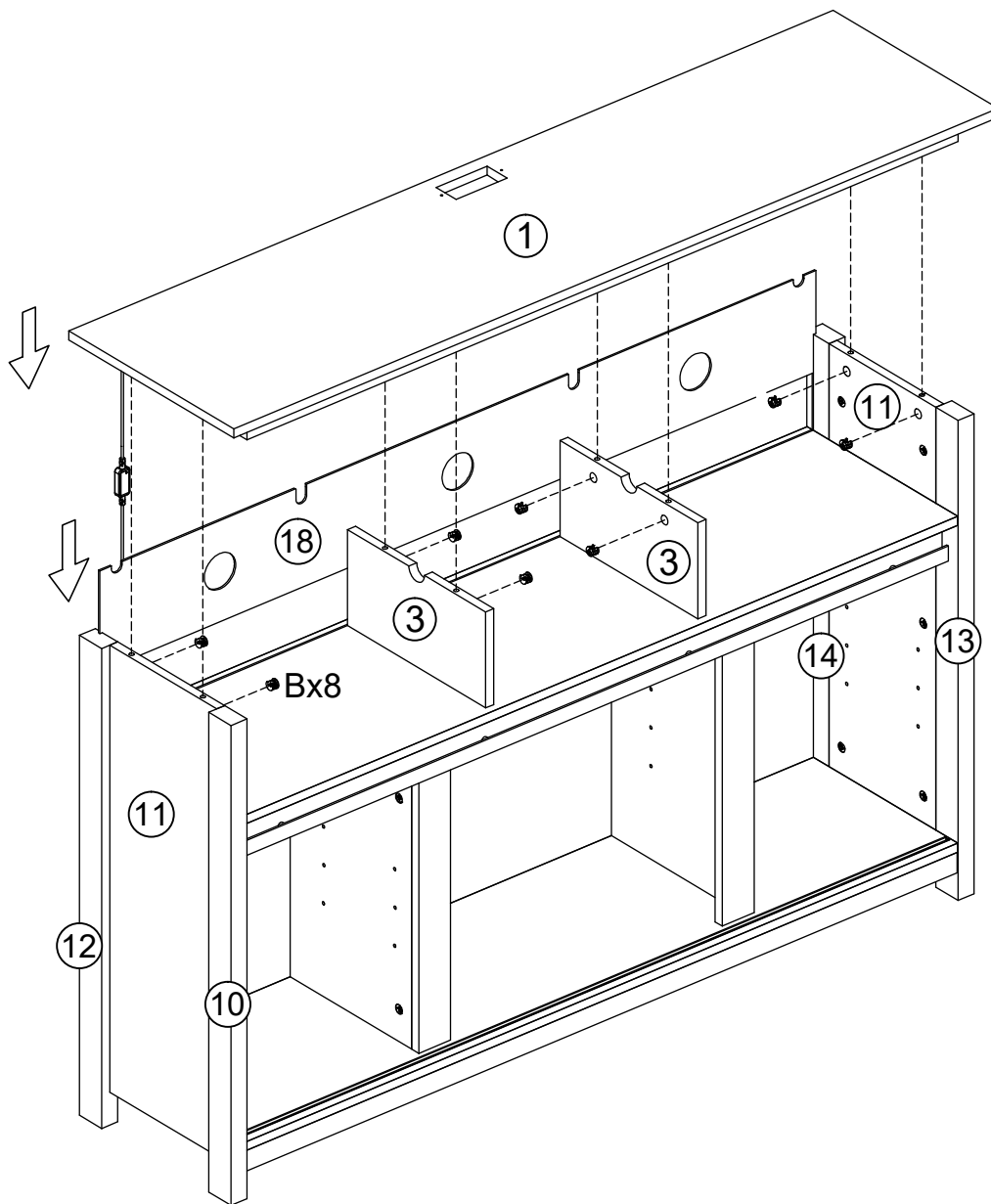

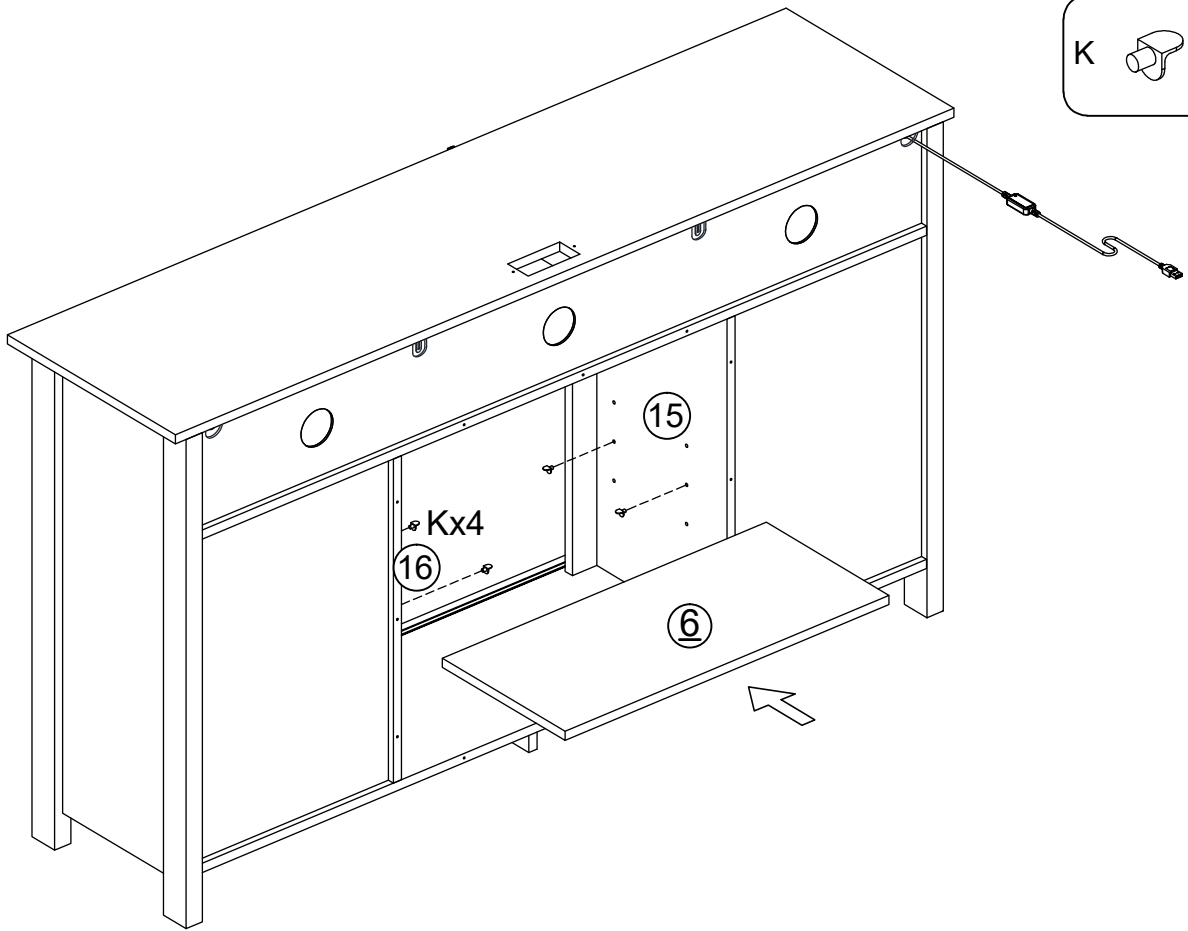

19

K  x4

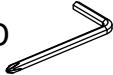

20

D  x1

G  x12

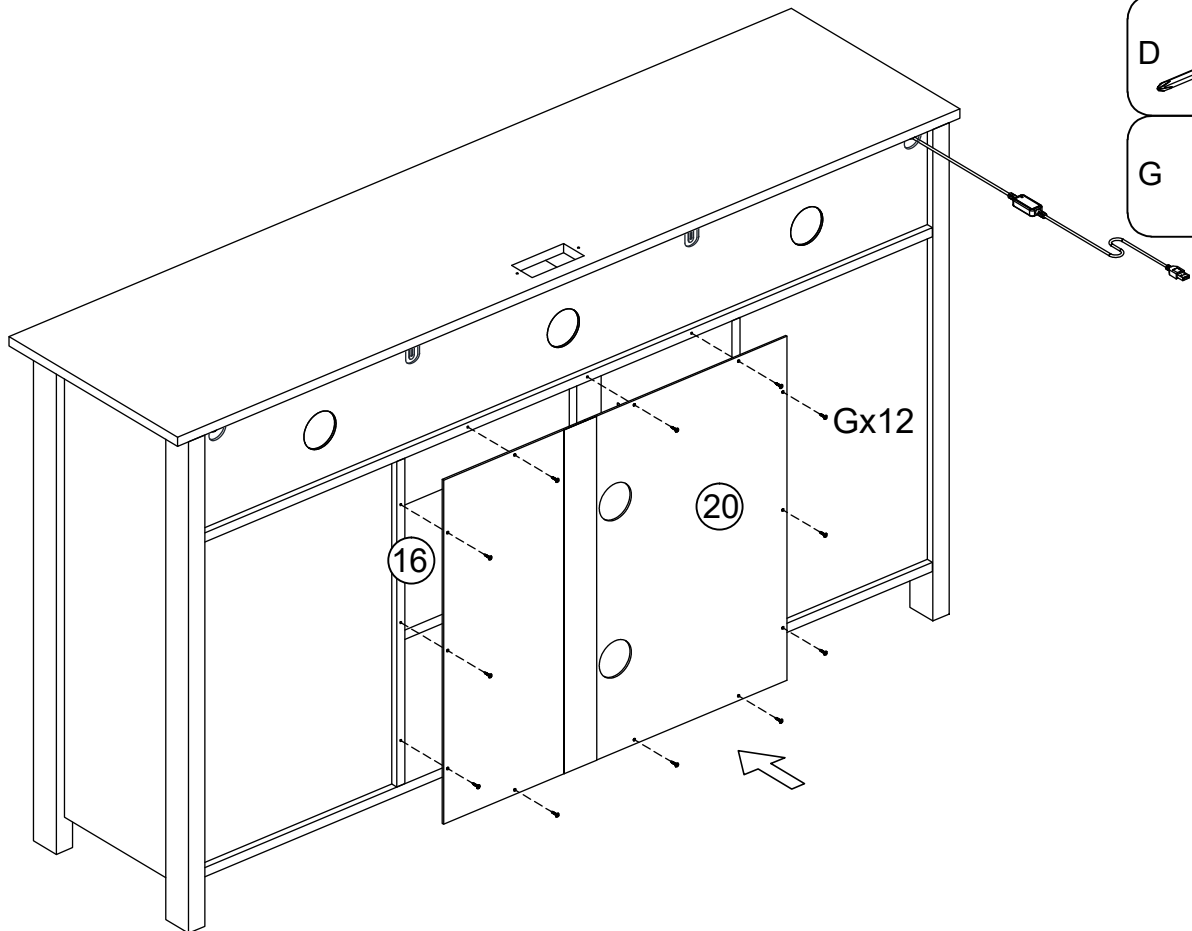

21

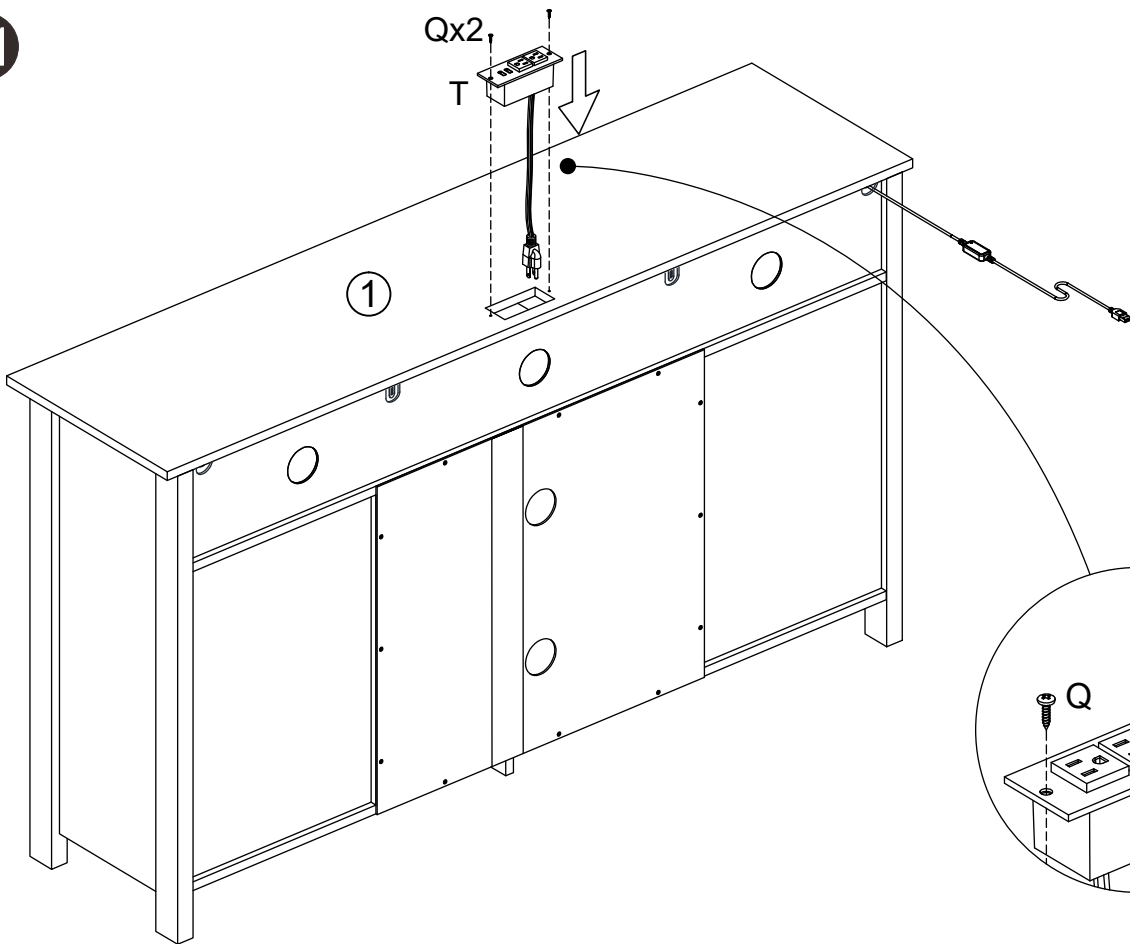

22

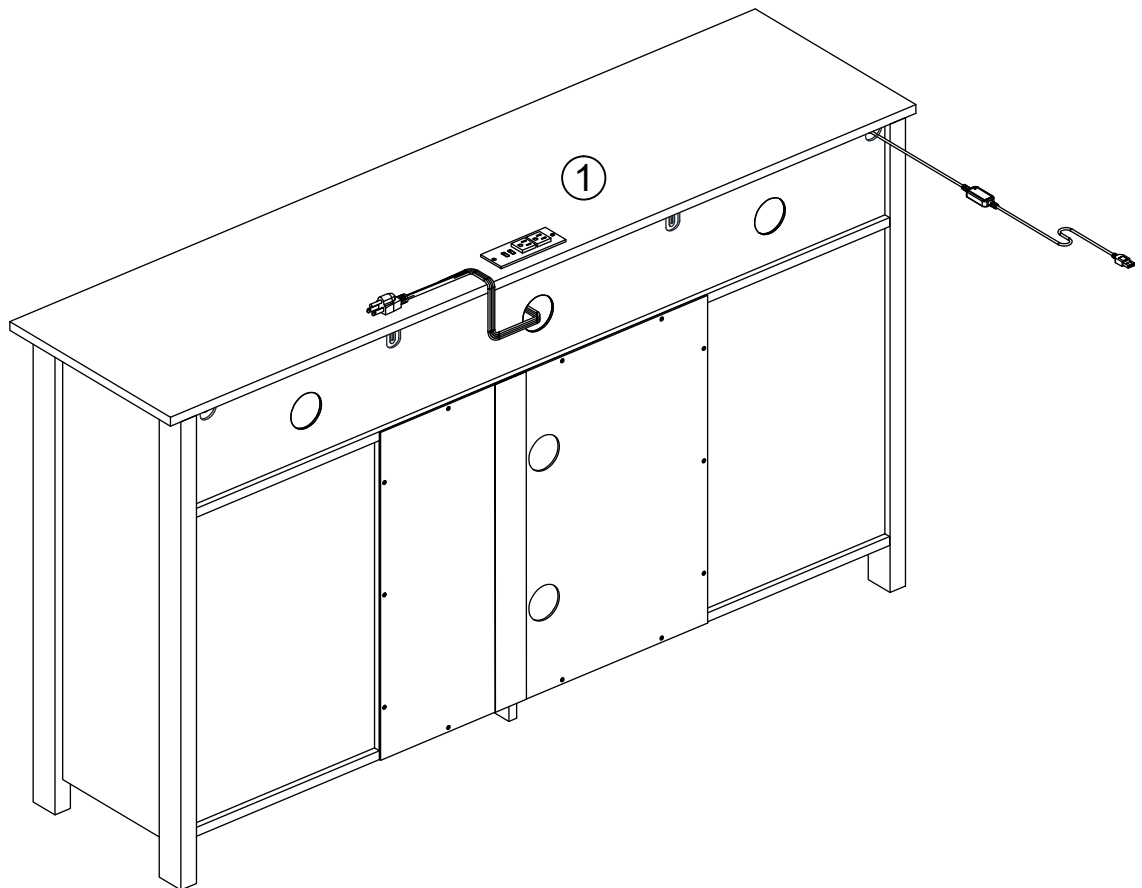

23

K x8

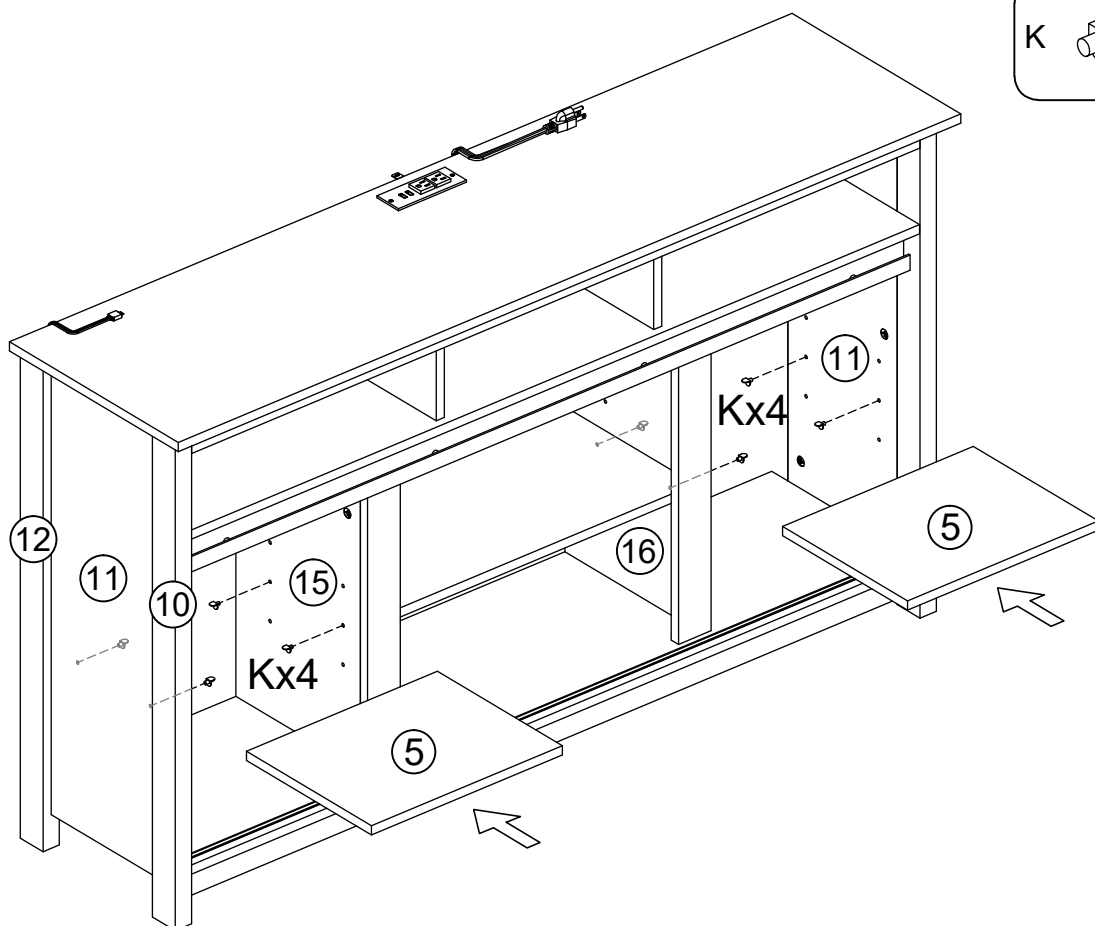

24

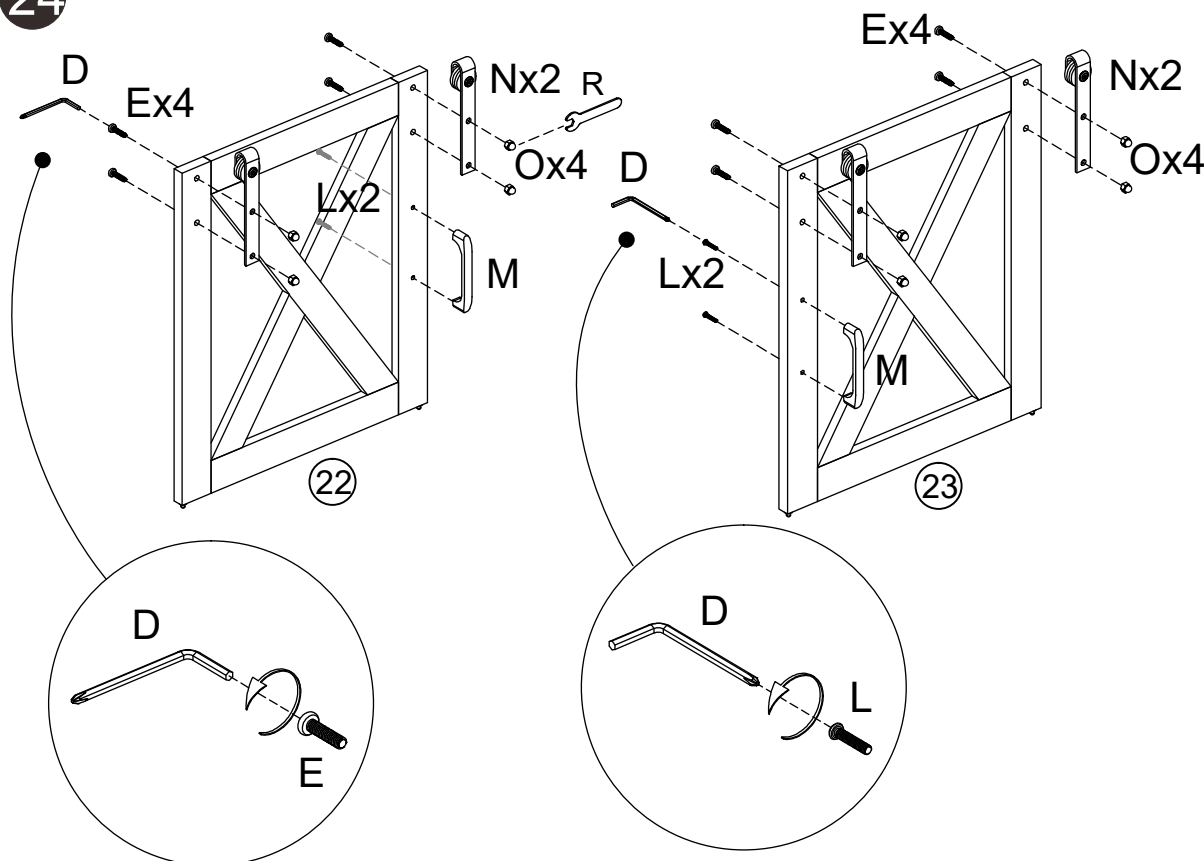

D x1

E x8

L x4

M x2

N x4

O x8

R x1

25

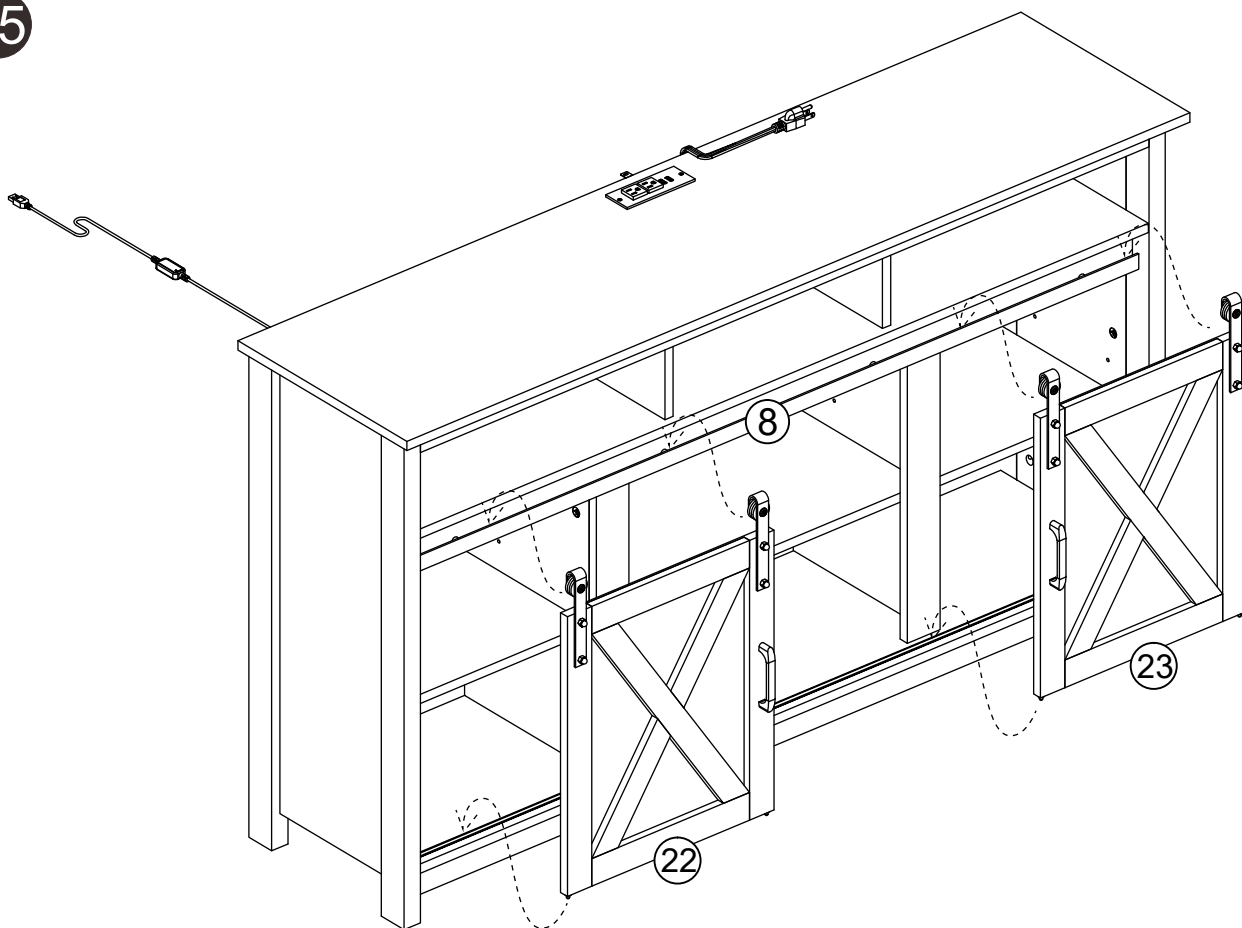

26

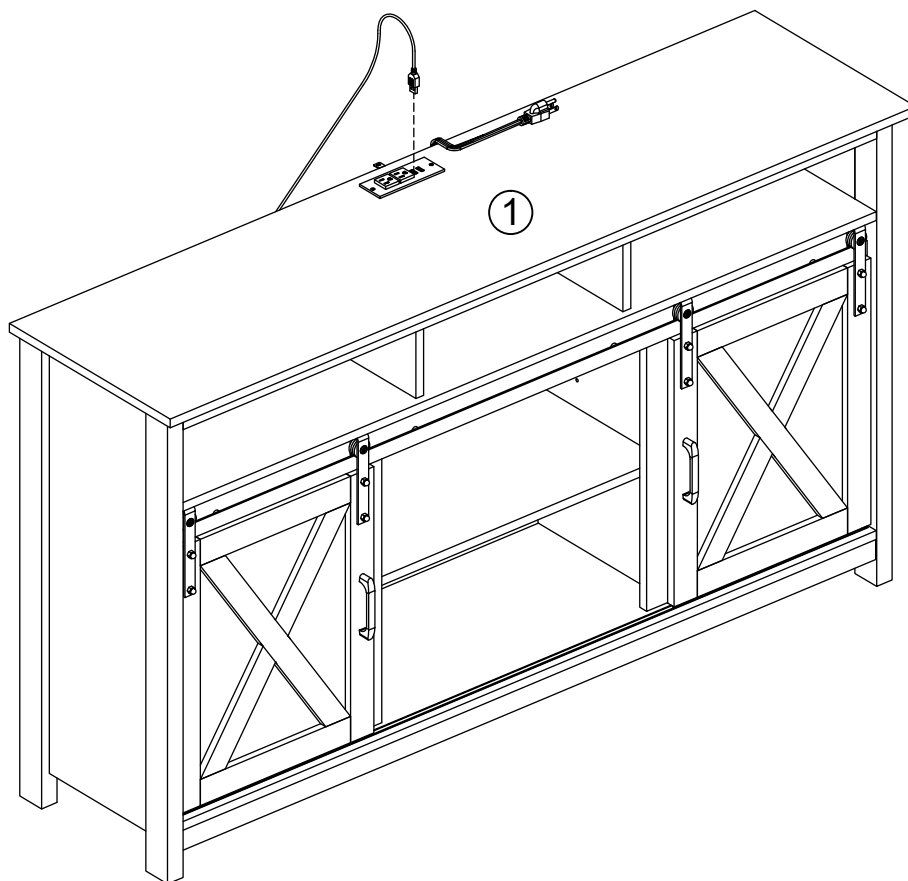

27

